

LED Headlight – Model 8770 Locomotive

0555711

Product Information

Description	8770 - 24/110V LED Locomotive Lamp
Height	170.00 mm / 6.69 in
Width	170.00 mm / 6.69 in
Depth	103.00 mm / 4.06 in
Shape	Round
Outer Lens Material	Glass
Outer Lens Color	Clear
Bezel Color	Black
Retrofits	PAR56
Minimum Operating Temperature	-40 °C
Maximum Operating Temperature	65 °C
Connector or Wiring	Standard Sealed Beam Style Screw Terminals
Product Weight	2.6 lbs / 1.18 kgs



Product Dimensions

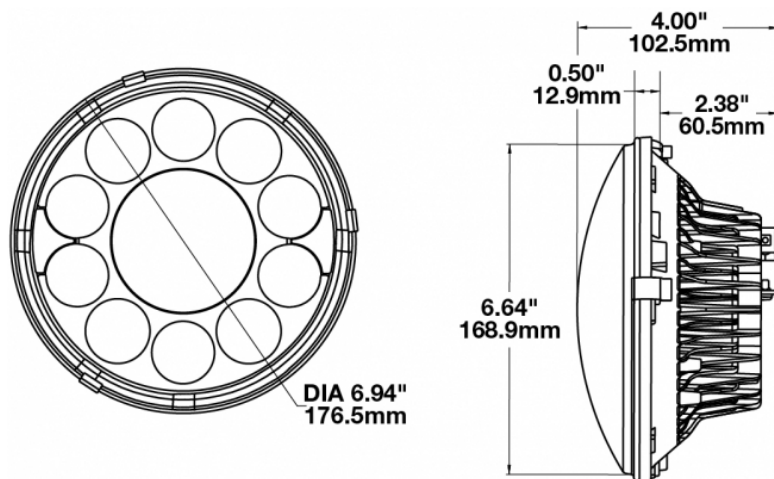

Electrical Specifications

Input Voltage	24-110V DC
Operating Voltage	24-110V DC
Transient Spike Protection	330V Peak @ 1 HZ-100 Pulses
Current Draw	1.00A @ 24V DC (Low Output) 0.45A @ 75V DC (Low Output) 0.30A @ 110V DC (Low Output) 2.10A @ 24V DC (High Output) 0.75A @ 75V DC (High Output) 0.55A @ 110V DC (High Output)

Photometric Specifications

Raw Lumen Output	2,200
Effective Lumen Output	2,040
Candela Output	260,000 Min.
Nominal LED Color Temperature	5000 K

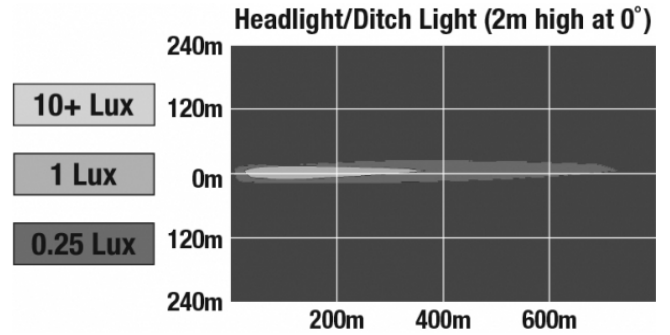

Additional Specifications

Warranty	Please refer to the Warranty Statement which is available for download on the website
Pack Quantity	1