

LED Stop, Tail, Turn & Backup Light – Model 281 0339011



Product Information

Description	Model 281 - 48V LED Signal Light - Red, Amber & White (Stop, Tail, Turn Signal & Reverse)
Height	215.90 mm / 8.5 in
Width	49.53 mm / 1.95 in
Depth	27.94 mm / 1.1 in
Shape	Rectangular
Outer Lens Material	Polycarbonate
Outer Lens Color	Clear
Housing Material	ABS
Housing Color	Black
Mounting Type	Low Profile Mount
Minimum Operating Temperature	-40 °C
Maximum Operating Temperature	65 °C
Connector or Wiring	12" Bare Leads
Product Weight	0.40 lbs / 0.18 kgs
Shipping Weight	1.80 lbs / 0.82 kgs



Product Dimensions

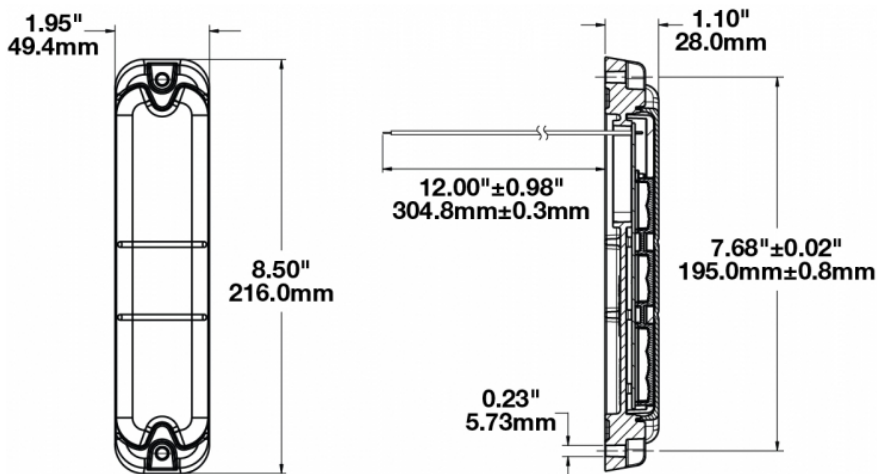

Electrical Specifications



Input Voltage	48V DC
White Wire	Backup
Yellow Wire	Turn
Red Wire	Brake
White/Red Wire	Tail
Black Wire	Ground
Current Draw	0.4A @ 48V DC

Photometric Specifications



Beam Pattern(s)	Signalization - Stop Signalization - Tail Signalization - Turn (Front) Signalization - Turn (Rear)
------------------------	---

Additional Specifications



IP Rating	IP67
Warranty	Please refer to the Warranty Statement which is available for download on the website
Pack Quantity	1