

LED Solar Flasher & Warning Light – Model 210

0647031

Product Information

Description	Model 210 - Amber Solar Flasher
Height	136.00 mm / 5.35 in
Width	147.10 mm / 5.79 in
Depth	21.00 mm / 0.83 in
Shape	Rectangular
Outer Lens Material	Acrylic
Outer Lens Color	Clear
Housing Material	Polycarbonate
Housing Color	Black
Minimum Operating Temperature	-40 °C
Maximum Operating Temperature	65 °C
Connector or Wiring	NA
Mating Connector	NA
Product Weight	0.40 lbs / 0.18 kgs
Shipping Weight	0.50 lbs / 0.23 kgs

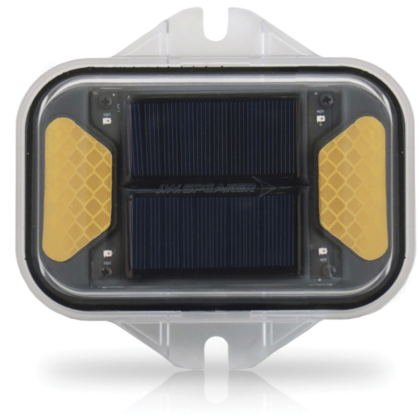

Product Dimensions

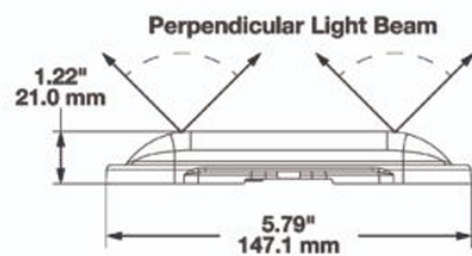
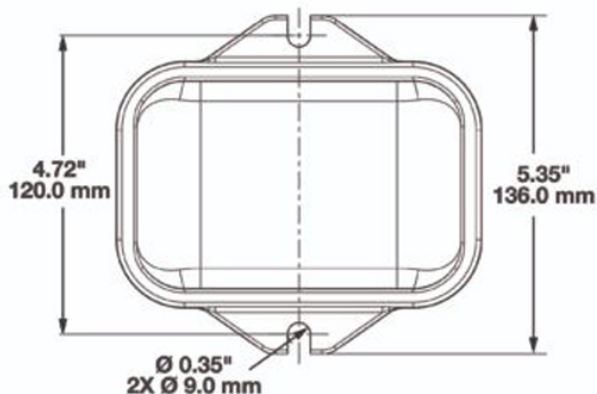

Electrical Specifications



Battery Run Time 120 hours

Battery Recharge Time 6 hours

Photometric Specifications



Candela Output 11

Additional Specifications



IP Rating IP69K

Warranty Please refer to the Warranty Statement which is available for download on the website

Pack Quantity 1